

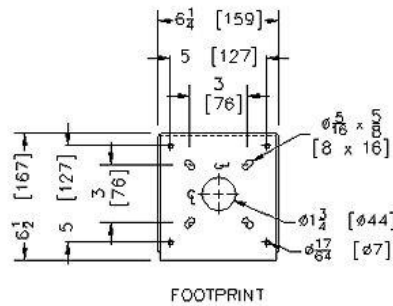

MAGUIRE BLENDER MODEL WSB-MB

Specifications

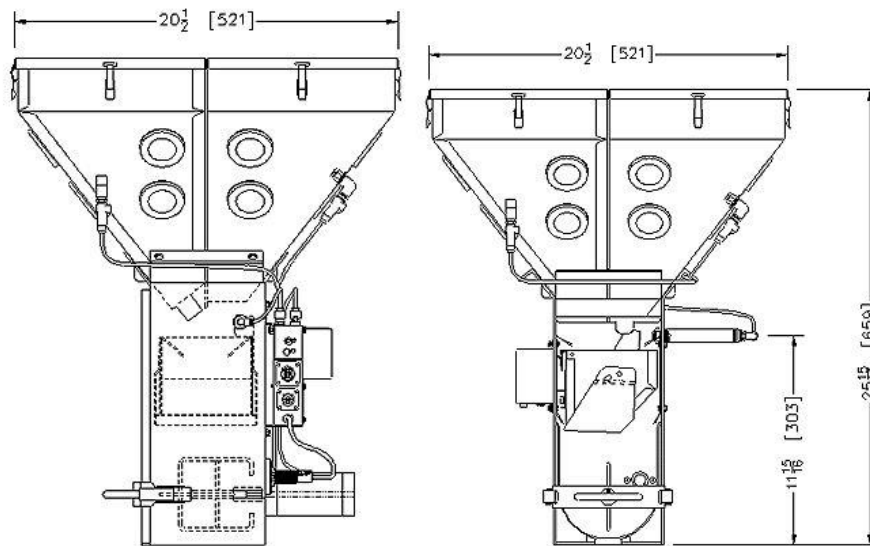

NOTE:
HOPPER CAPACITY IS APPROX .3
CU FT [8 LITRES]

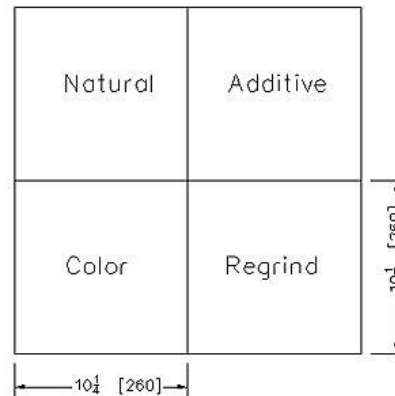

Model	Batch Size	Components	Slide Gates	Vertical Valves	Capacity	Overall Dimensions	Overall Weight
WSB-MB	0.9 lb	4	0	4	up to 140 lb/hr	16x16x23.5 (in)	50 lb
MICRO	(0.4 kg)				(up to 64 kg/hr)	410x410x600 (mm)	(23 kg)

This list is subject to change without notice.

This specification sheet is confidential and is just a guide. Although obtained from sources deemed reliable, Premier Equipment makes no warranty or guarantee as to the accuracy of the information herein contained. It is the purchaser's responsibility to verify specifications.

PREMIER EQUIPMENT 29225 CHAGRIN BLVD, SUITE 330 BEACHWOOD, OH 44122

www.buypremierequipment.com

Ph: (216) 593-7000 Fax: (216) 593-0557 Toll-free (888) 897-1197